

**CHER
MÉTIS**
WINTER SCHOOL 2023
PARIS EST EAVT

CHER

MÉTIS

**MANUEL DE
RÉPARATION
REPAIR
*MANUAL***

CHER MÉTIS

curated by Francesca Gotti

**Winter School 2023
Paris Est EAVT**



CHER MÉTIS

FR

Dans la tradition rurale, pendant l'hiver, les familles se réunissaient dans la grange pour réparer les vêtements, les outils agricoles et les meubles, tandis que des ouvriers parcouraient les villages en tant qu'experts en réparation de poteries et de parapluies. Comme le montre la série de photos "Bastard chairs" (2002) de Michael Wolf, la réparation continue d'être une activité quotidienne pour les personnes qui doivent lutter contre l'obsolescence programmée des produits que le marché propose.

CHER MÉTIS est une expérience collective de réparation, de l'échelle de l'objet à celle de l'espace. CHER MÉTIS explore le territoire, trouve des ressources mises au rebut, imagine de nouveaux usages et de nouvelles significations, collecte des souvenirs et invente de nouvelles histoires. CHER MÉTIS crée des connaissances, prend soin les uns des autres, active le potentiel des artefacts. Retracer l'ensemble du processus de travail de chaque artefact est une façon de raconter la relation entre la personne qui répare l'objet et l'objet lui-même, de partager l'expertise requise, les étapes nécessaires pour transformer un objet rejeté en une nouvelle histoire.

CHER MÉTIS est une ode aux formes hybrides des choses, des transformations, de tout ce qui reste et qui se stratifie à travers le temps. MÉTIS est aussi un terme grec classique qui désigne la connaissance acquise par l'expérience pratique. CHER MÉTIS est un acte anarchique de salut, un acte d'amour pour les objets qui habitent nos vies, un acte d'amour pour ce que nous produisons, abandonnons et redécouvrons sans cesse.

EN

In rural tradition, during winter time, families used to gather in the barn to mend clothes, repair farming tools and fix furnitures, while workers would travel around villages as experts of pottery and umbrellas repairing. As Michael Wolf photo series "Bastard chairs" (2002) portrays, repair continues to be a daily activity for people who needs to fight the programmed obsolescence of the products that the market offers.

CHER MÉTIS is a collective experiment of repairing, from the scale of the object to that of the space. CHER MÉTIS is exploring the territory, finding discarded resources, imagining new uses and new meanings, collecting memories and inventing new stories. CHER MÉTIS is creating knowledge, taking care of each other, activating the potential of artefacts.

Tracing the entire working process of each artefact is a way to narrate the relationship between the person repairing the object and the object itself, to share the expertise it requires, the steps it take to turn a rejected object into a new story.

CHER MÉTIS means "Dear Mestizo", an ode to the hybrid forms of things, of transformations, of all that remains and that stratifies through time. MÉTIS is also a classic Greek term that designates knowledge acquired through practical experience. CHER MÉTIS is an anarchic act of salvation, an act of love for the objects that inhabit our lives, an act of love for what we produce, abandon, and rediscover over and over.



CHER METIS

In order of appearance

FAMILY TOASTER
Elisa Venant

CINEMA CABINET
Lise Fourneyron

DOMESTIC BENCH
Elisa Venant + Axel Cutté

FARMING DRAWER
Quentin Martinet

MUSIC SCULPTURE
Mathis de Berranger

NOMADIC CHAIR
Flavy Marimon + Joanne Haerens

RITUAL BOWL
Imara Garine

ALCOHOLICS ANONYMOUS
Gaspard Besson

CEMO MACHINE
Margot Genieys + Corentin Trzupek

STAGE CHAIR
Laure Catala

TREE TABLE
Lise Millet + Lila Parent

UNISEX LOCK
Axel Cutté + Corentin Trzupek

UNIVERSAL SEAT
Fabien Aubert

LEISURE TABLE
Maxence Poirier

FAMILY TOASTER



FAMILY TOASTER

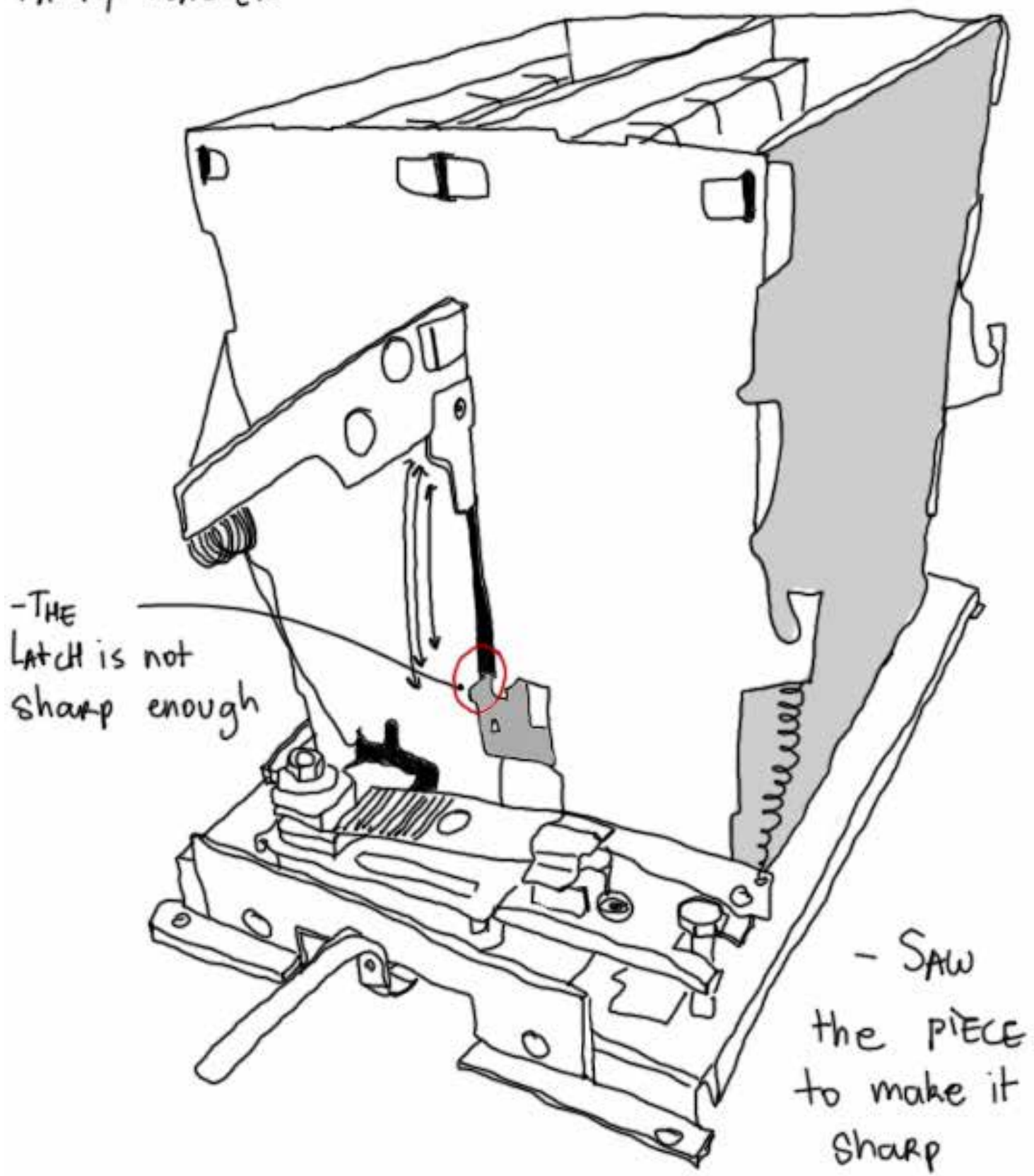

- DISMANTLE THE TOASTER WITH A SCREWDRIVER

STEP 1

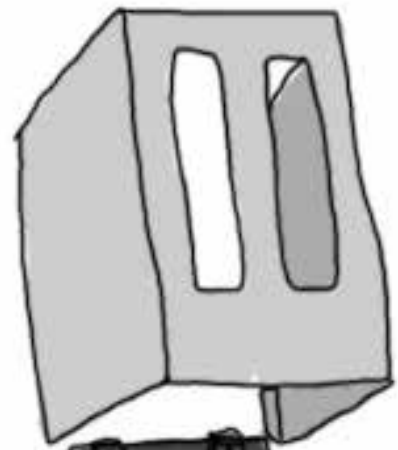
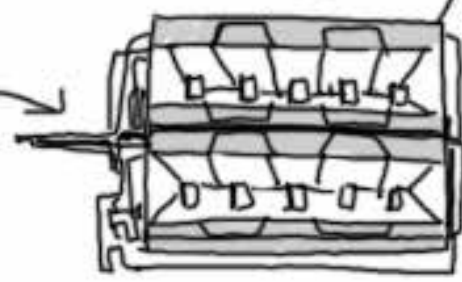
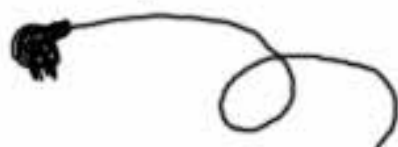

STEP 2

- FIND THE BROKEN PIECE AND USE A TOOL FOR SANDING METAL



→ Not enough sharp

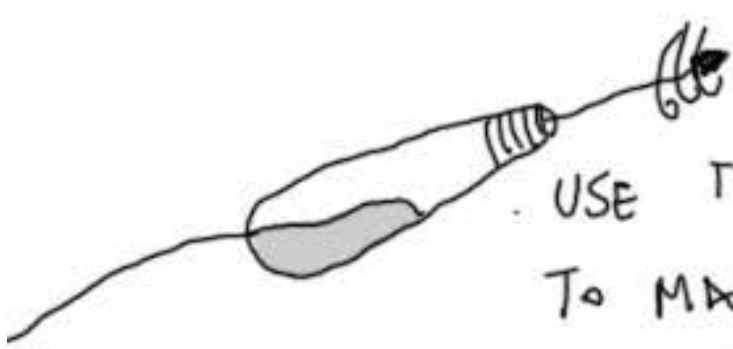

USE THE TOOL TO MAKE THE NEW PIECE

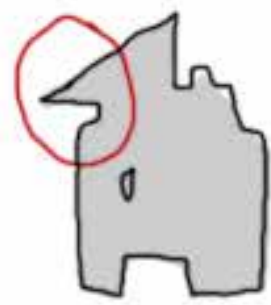

CINEMACABINET



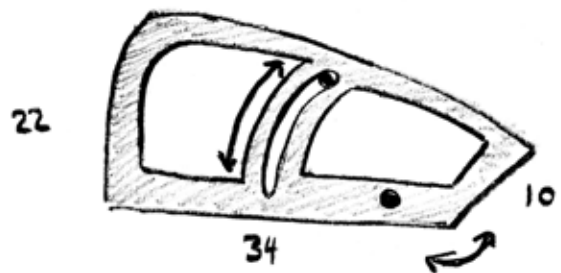
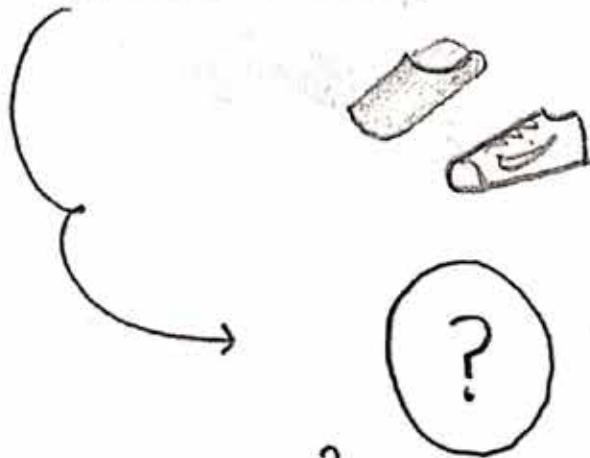
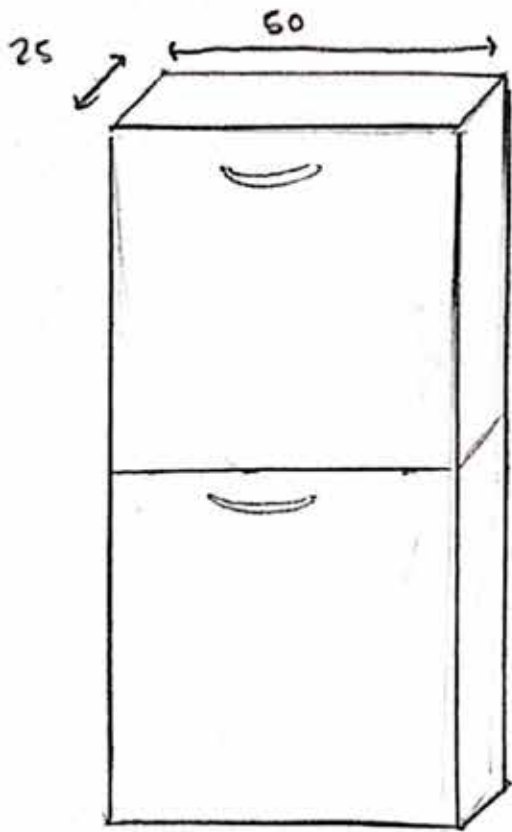

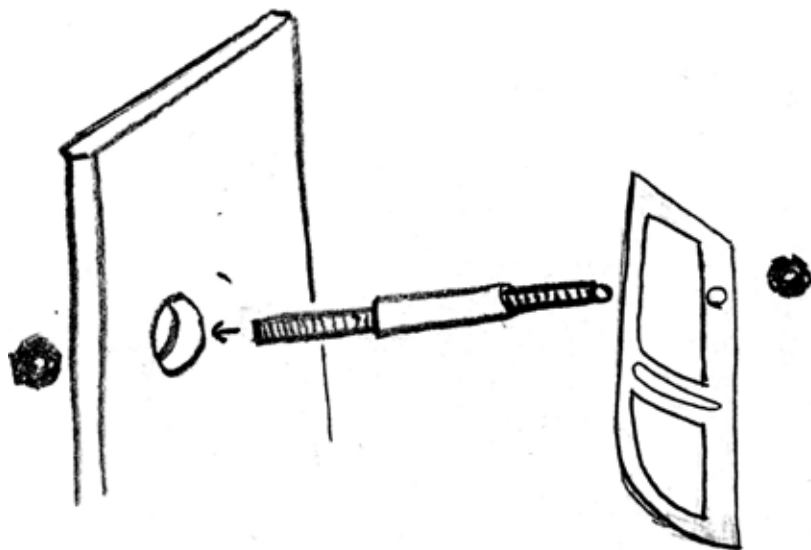

DOMESTIC BENCH



DOMESTIC BENCH

To REPAIR AN OLD BENCH WHO WAS IN THE GARAGE SCHOOL.

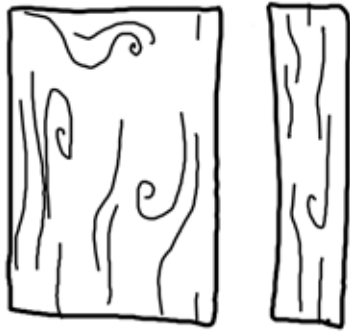
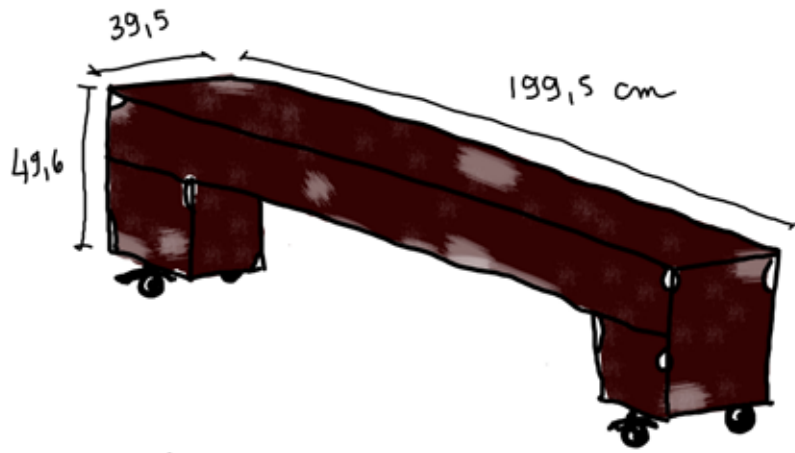

- FIND PLYWOOD

AND

- BROKEN CHAIRS

→ DISMANTLE THE CHAIR



BOLT

BACKSIT & OTHER PIECES



THE UNDERSIDE OF THE CHAIR

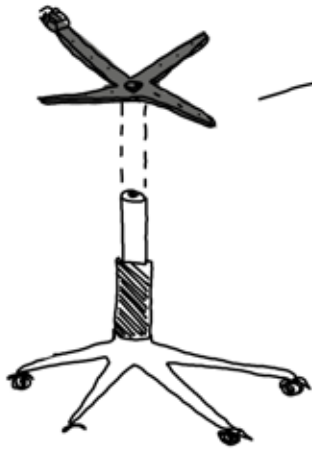

WITH HELP OF



COMBINE EVERYTHING TO CREATE THE BACKSIT OF THE BENCH.

NOW THINK ABOUT THE SIT

- SEW CUSHIONS

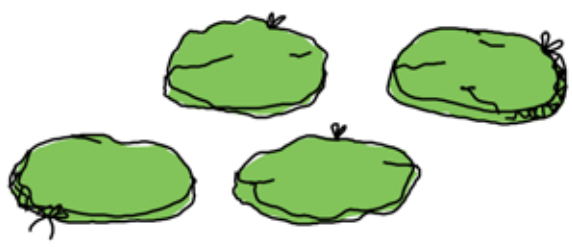
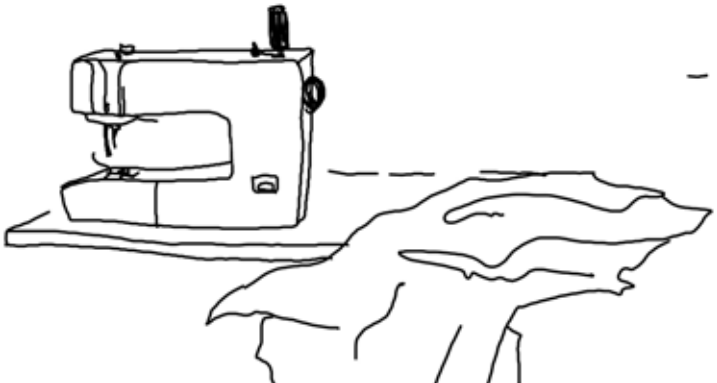

WITH A HAMMER, NAIL
THE PLYWOOD BOARD TO
THE BENCH

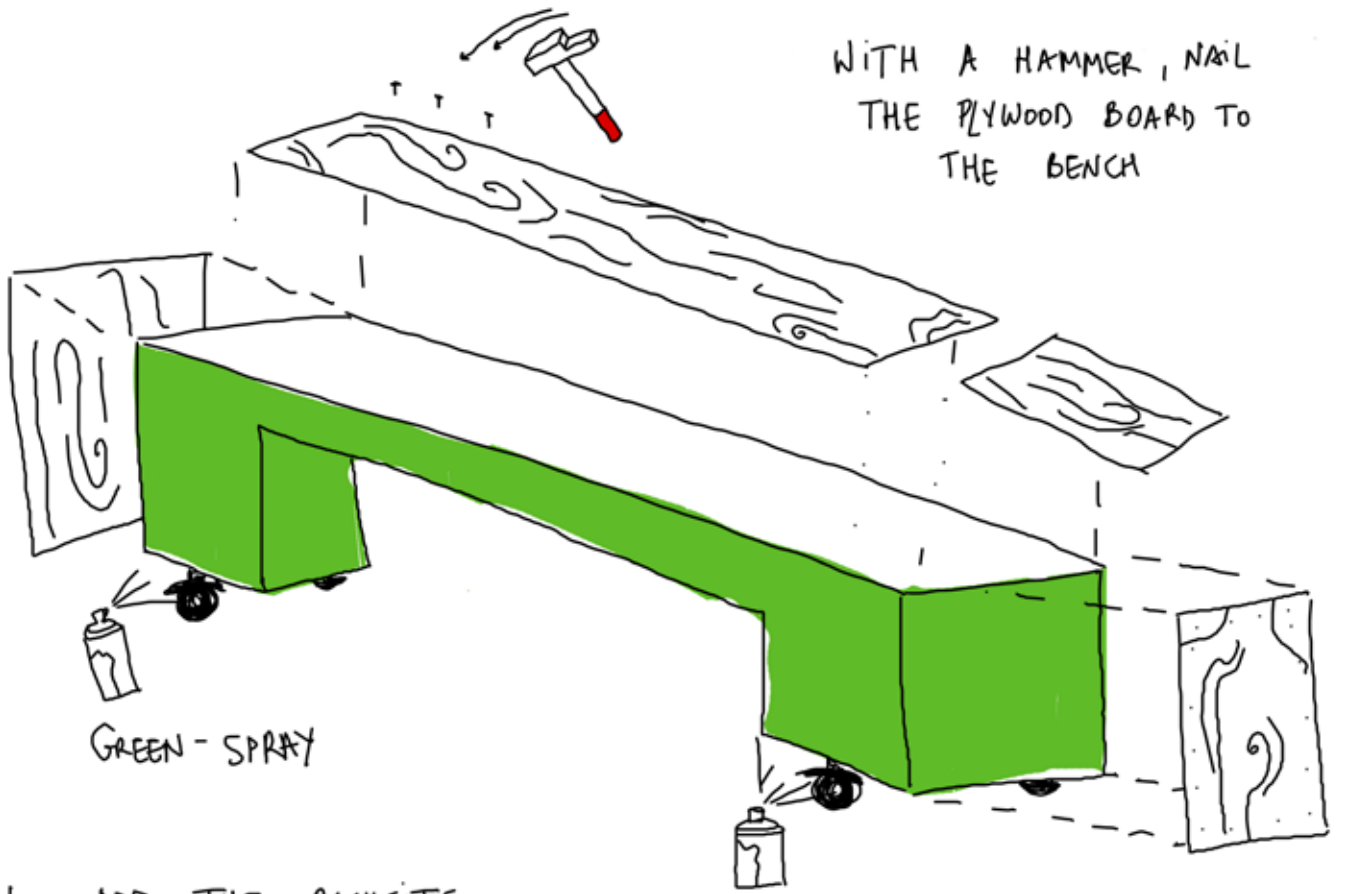

- THEN ADD THE BACKSITS

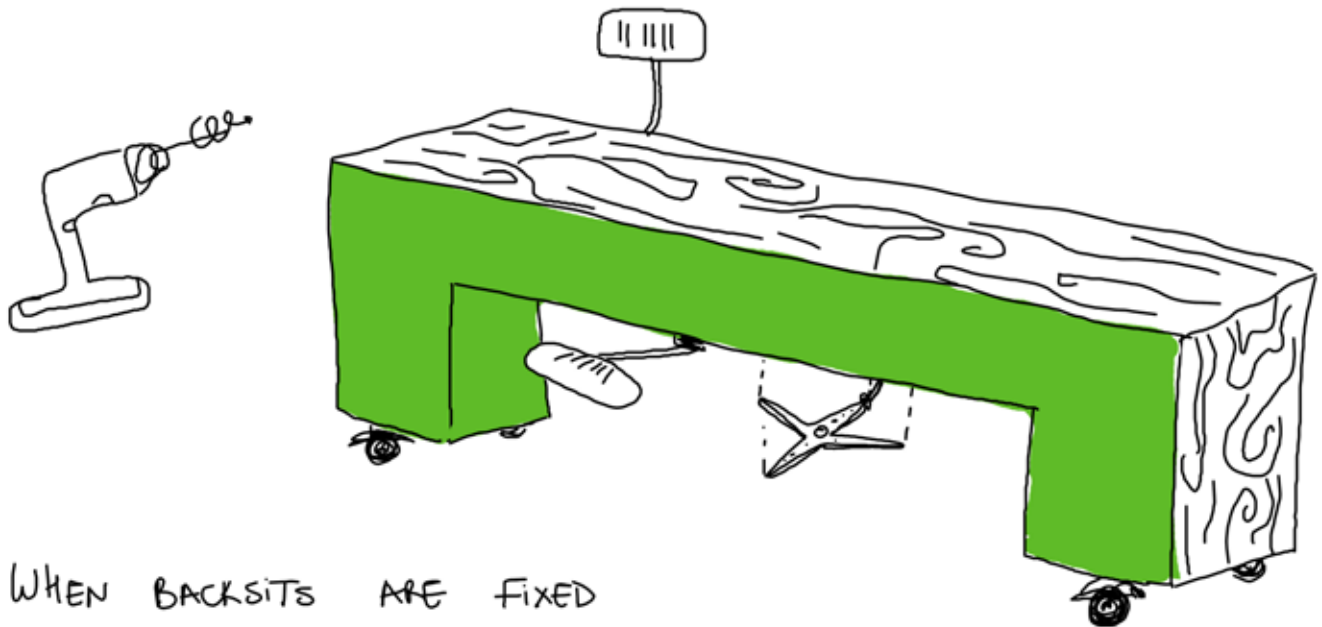

- WHEN BACKSITS ARE FIXED
ARRANGE THE CUSHIONS

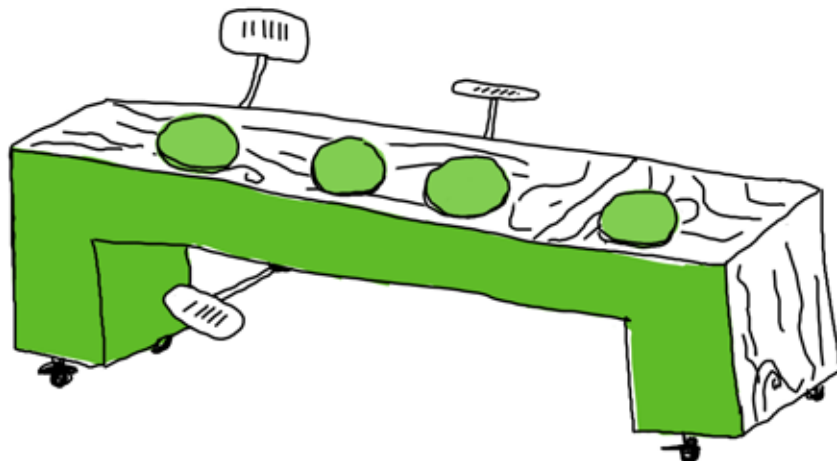

FARMING DRAWER



Farming Drawer

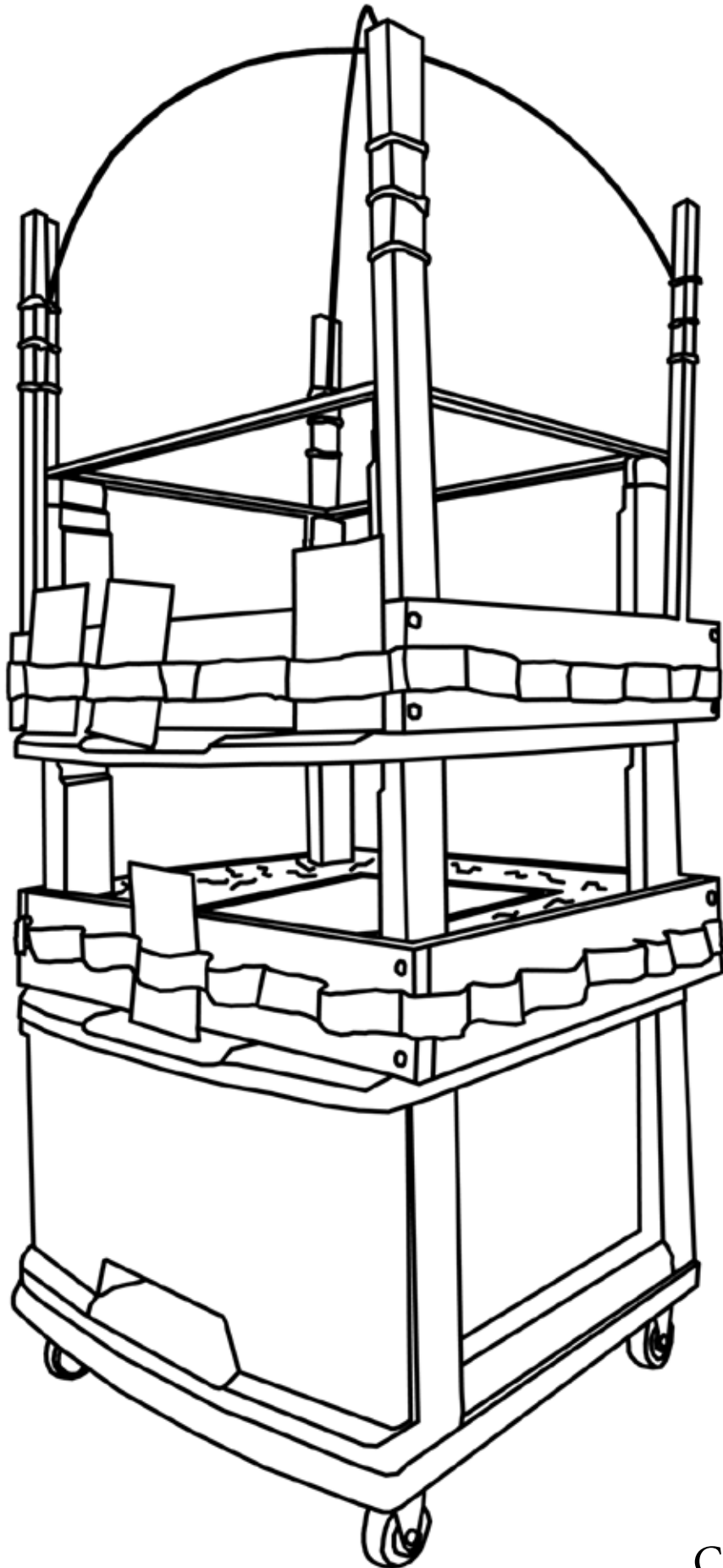

Cher Métis
Quentin Martinet

Goals and presentation

The objective of this workshop is to find a broken object and repair it to give it a second life.

I accept my mission and I seek my object. I walk around and my gaze crosses the path of this plastic piece of furniture with missing drawers and a painting to refresh.

The layout of this modular and vertical furniture gives me the idea of transforming it into a vertical garden. The plastic furniture combines with the varnished wood to accommodate aromatic herbs and plants.

Narrative text

Hi I'm Henri, I live in an apartment and farming is essential for me. This furniture is therefore a great idea. Follow me !

It's February 15, it's time to plant my different aromatic herbs. My drawer closet is on my living room because it's still too cold. However inside I can already use it to replant.

Today, It's April 7 and I decide to take out my vertical garden. My rosemary has grown well but it needs to see more light and air from outside. However I am afraid for the nights so I cover the furniture with the protective tarpaulin.

July 24, 2.p.m : I decide to use my pruner to remove some of my weeds because they are taking up too much space.

October 12, it's cold outside and my herbs have all been used up this season it's time to tidy up my garden.

Initial object

A black plastic drawer shelf

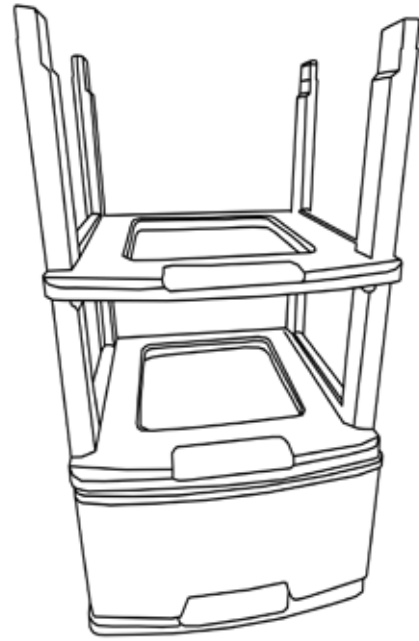

Only one drawer and the modules above are non-existent
The furniture is dirty and the paint is peeling off

Wooden planters



With 4 woden planks, we form the outside of the planter which rests on the plastic cabinet. Then with 4 other boards, the interior of the planter is formed.



This device is made a second time to form 2 planters.



Roller stand



This extension allows the furniture to roll



Painted medium plate



Wheel : 4 wheels are attached to the support



4 wooden branches

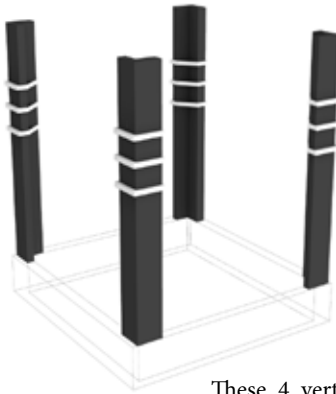

These 4 vertical planks are used to hang the two piano wires serving as a roof

Twine bows
3 different
positions of the
rods for the roof



Piano wire for
the roof

Tool pockets

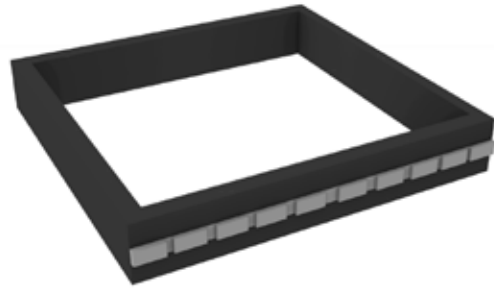

With tape stapled on the wooden planters, tool pockets are formed

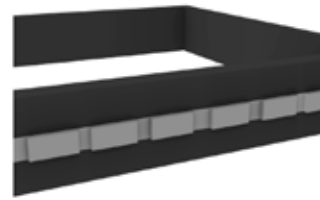

The ribbon goes around the planter and allows the user to store their belongings there

Soil filling



Filling the plastic drawer, serving as a pot for the plant

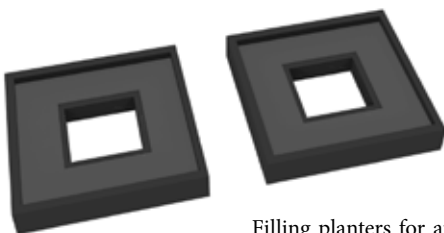

Filling planters for aromatic herbs

To conclude, this week of workshop allowed me to discover a vision that interested me enormously.

It's very important these days to give priority to recovery and repair rather than buying new items. First of all for economic reasons but above all for ecological reasons.

This week we made furniture from broken objects, this allowed us in particular to make beautiful objects but above all to give life to an object which has a first memory and life.

With this completely different utility, the vertical farm will honor this plastic piece of furniture which looked very industrial and had a mediocre personality.

Thanks for this week of discovery and sharing

MANUAL :

Farmer Drawer

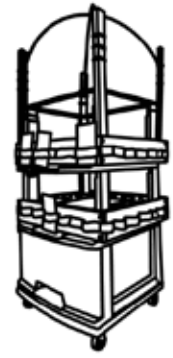

Initial object : a black plastic drawer shelf



Wooden stand



Wheel
x4



Moving support for
farmer



Varnished wooden
planks
x 4 (interior)
x 4 (exterior)

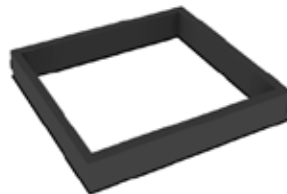

Assembly

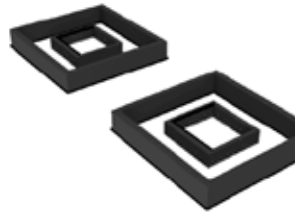

Planters
x2



Extension of the sides.
3 twines for the roof
positions
x4



Piano wire : roof
x2



Tool pockets
Ribbon : 110 cm
x2

MUSICSCULPTURE



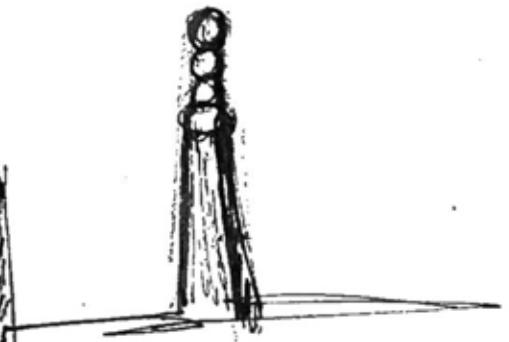
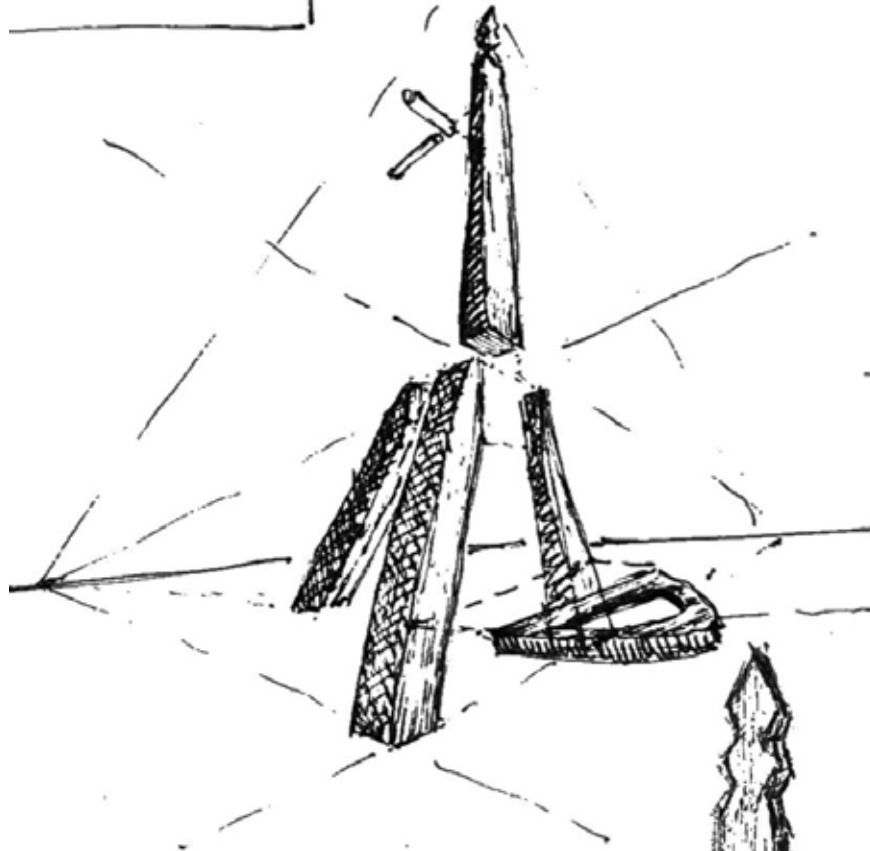

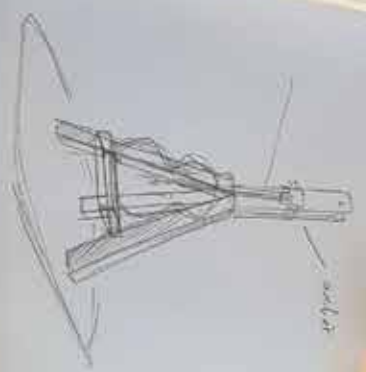

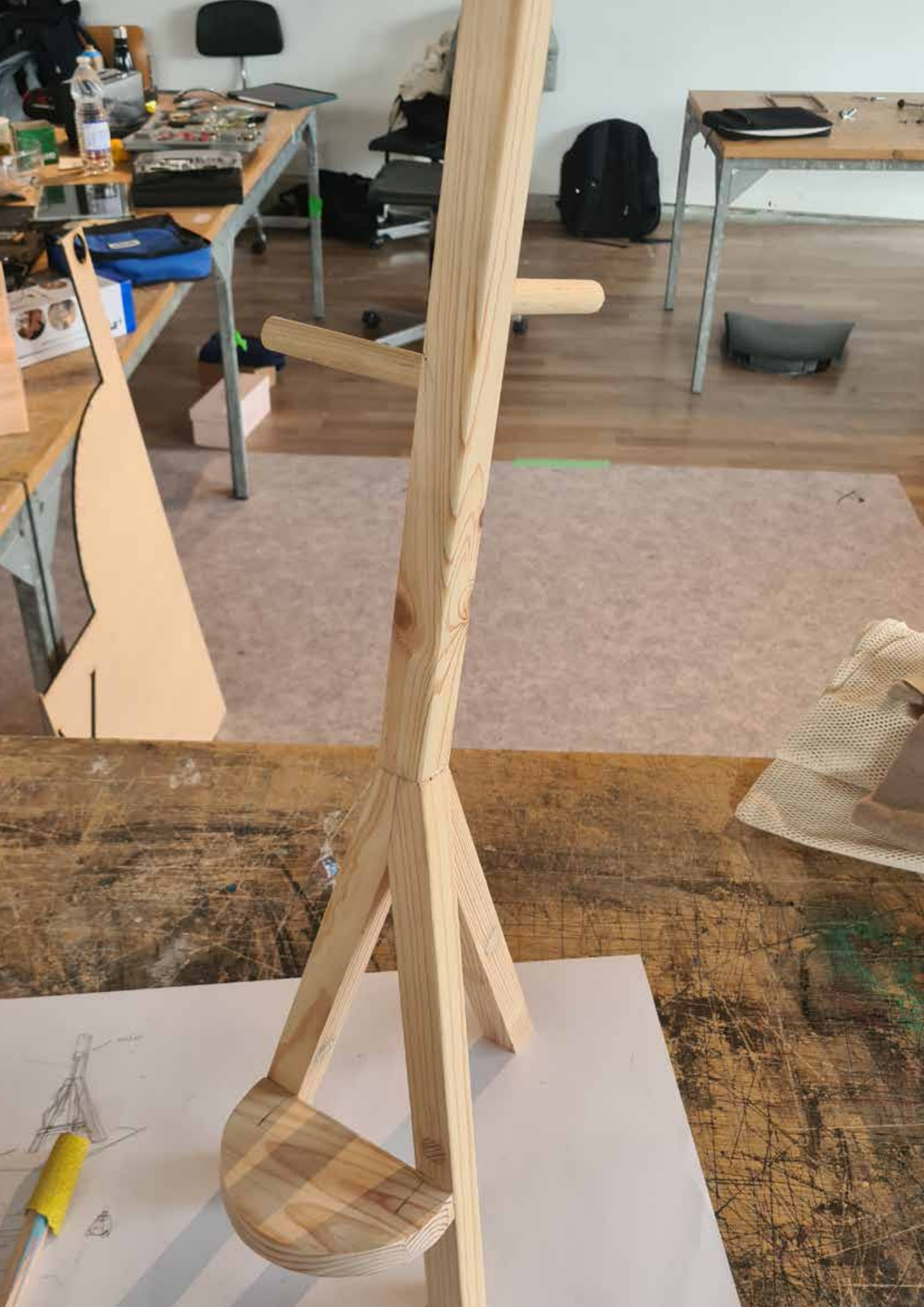

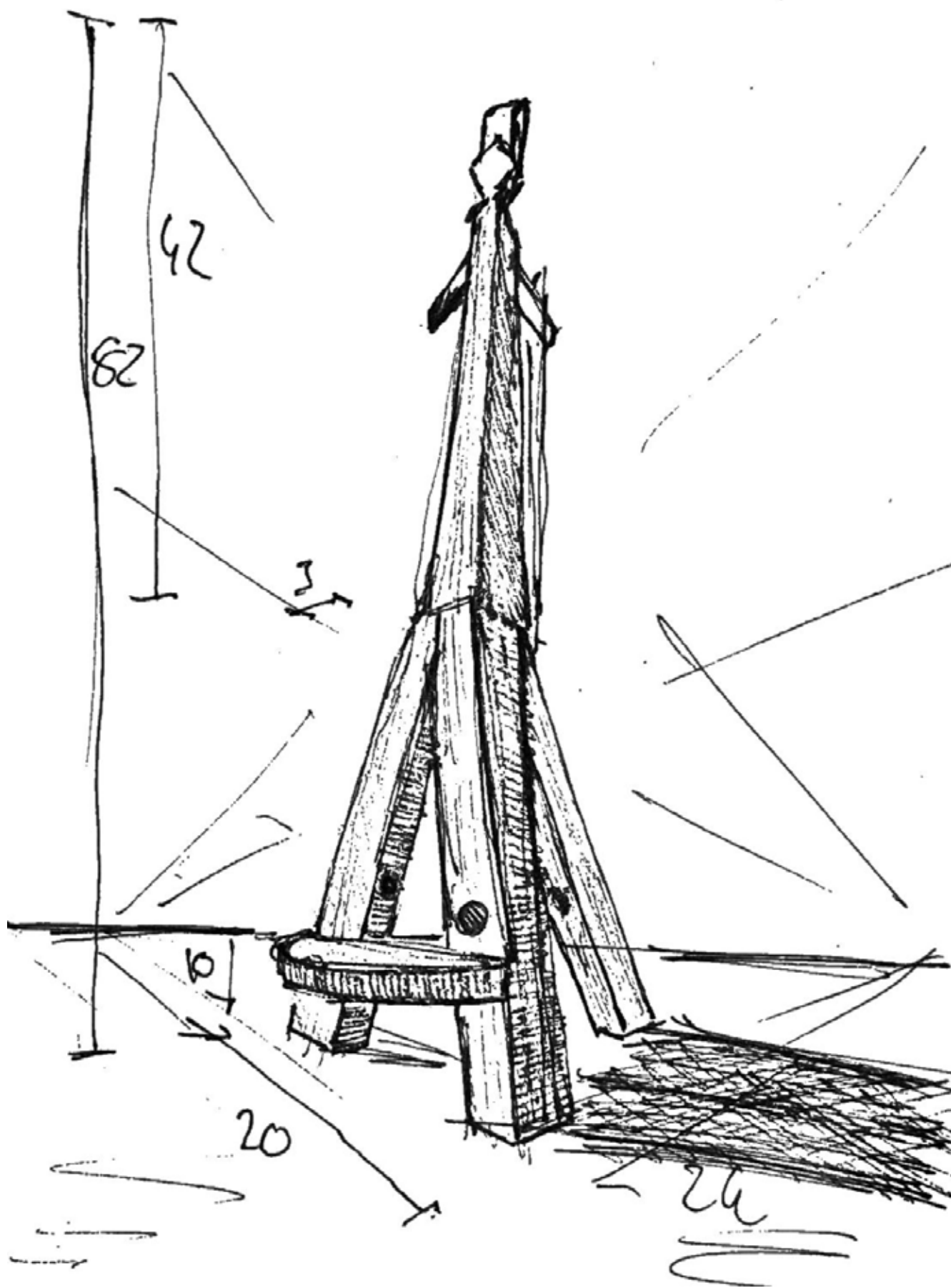

NOMADIC CHAIR





NOMADIC CHAIR

Flavy MARIMON - Joanne HAERENS

ARMATURE FRAME



.1

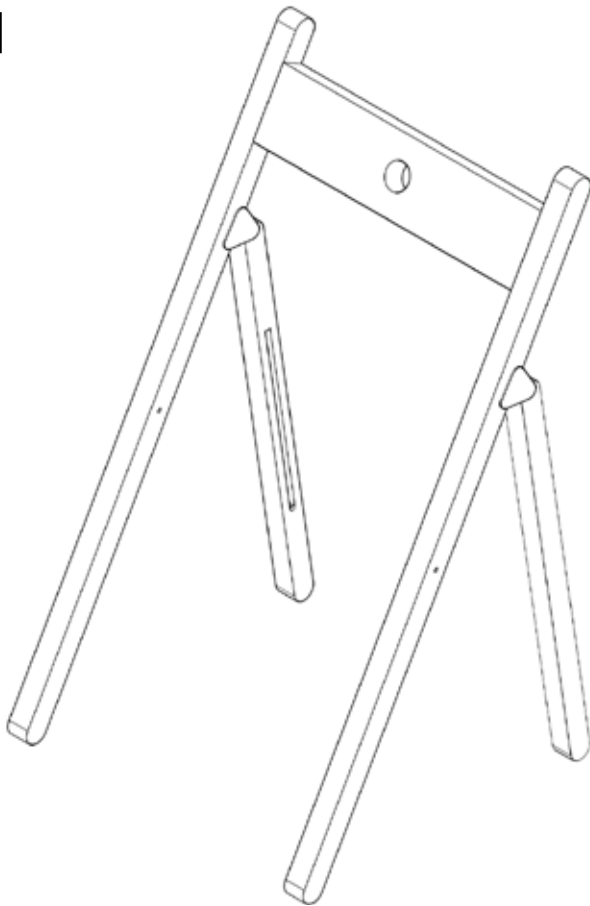

Pour l'armature, récupérez celle d'un ancien meuble en mauvais état et récupérez la partie qui vous intéresse. Pour la remettre à neuf, poncez et vernissez là.

For the frame, take the frame from an old piece of furniture in poor condition and remove the part that interests you. To refurbish it, sand and varnish it.

.2



Afin de solidifier l'armature, des barres d'acier peuvent être utilisées. En les enfonçant avec un marteau et en sécurisant avec de la colle cela crée un contreventement à la chaise.

To strengthen the frame, steel bars can be used. By driving them in with a hammer and securing with glue this creates a bracing of the chair.

ASSISE

SEAT

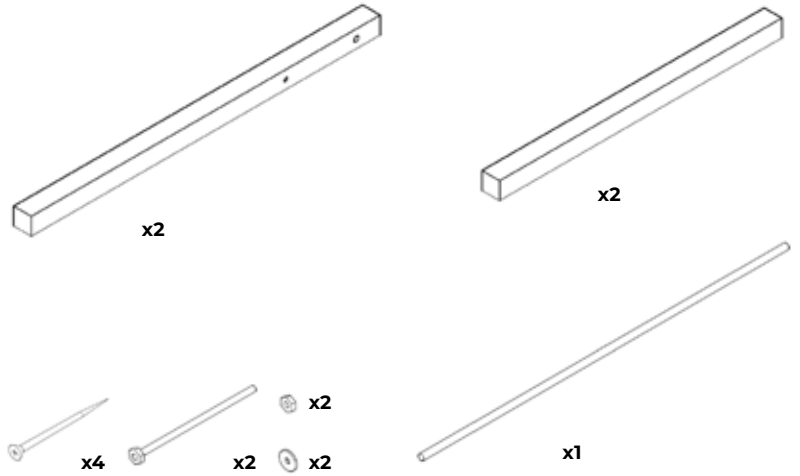
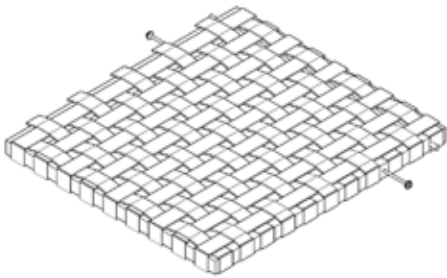

.1

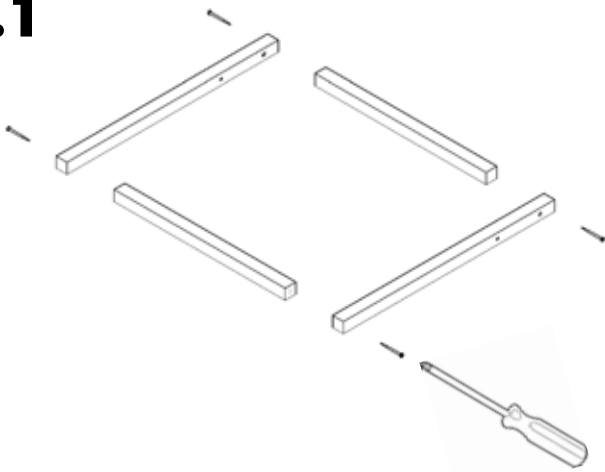

Pour créer l'assise, un cadre doit être créé. Montés avec des vis, les tasseaux en bois sont dimensionné pour la chaise.

To create the seat, a frame must be created. Mounted with screws, the wooden slats are sized for the chair.

.2

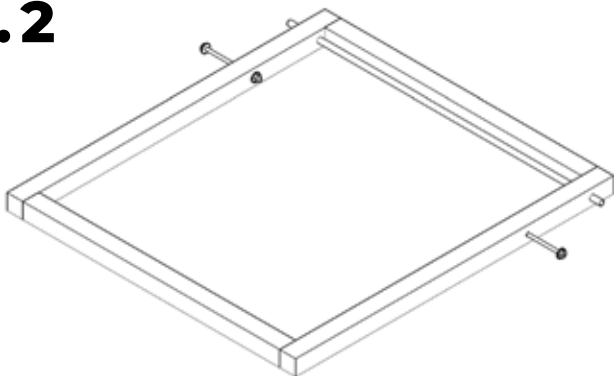

À la suite nous pouvons insérer les éléments nécessaires à la fixation de l'assise sur la structure et vérifier sa solidité

Then we can insert the necessary elements to fix the seat on the structure and check its solidity.

.3

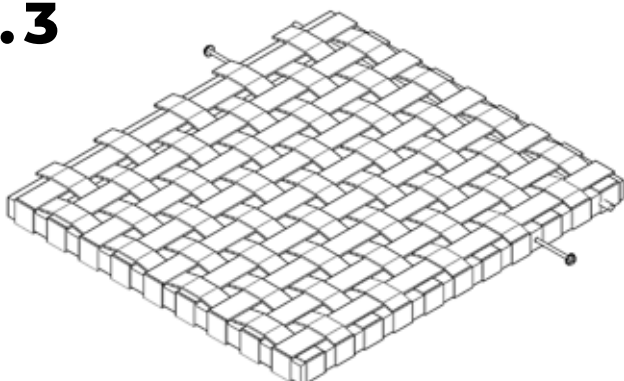

Afin de terminer l'assise un maillage en sangle est effectué. Celui-ci est fixé à l'aide d'agrafe à l'intérieur du cadre en bois.

To complete the seat, a webbing mesh is made. This is attached to the inside of the wooden frame with staples.

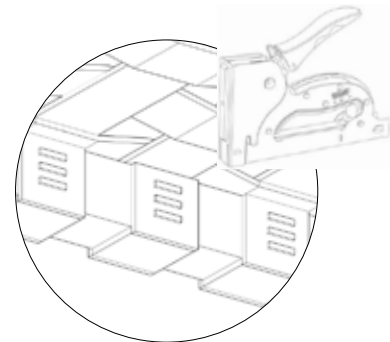

CHAISE

CHAIR

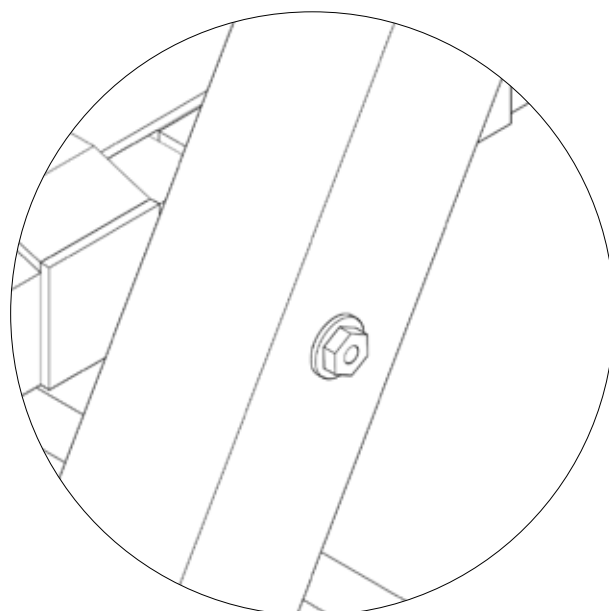
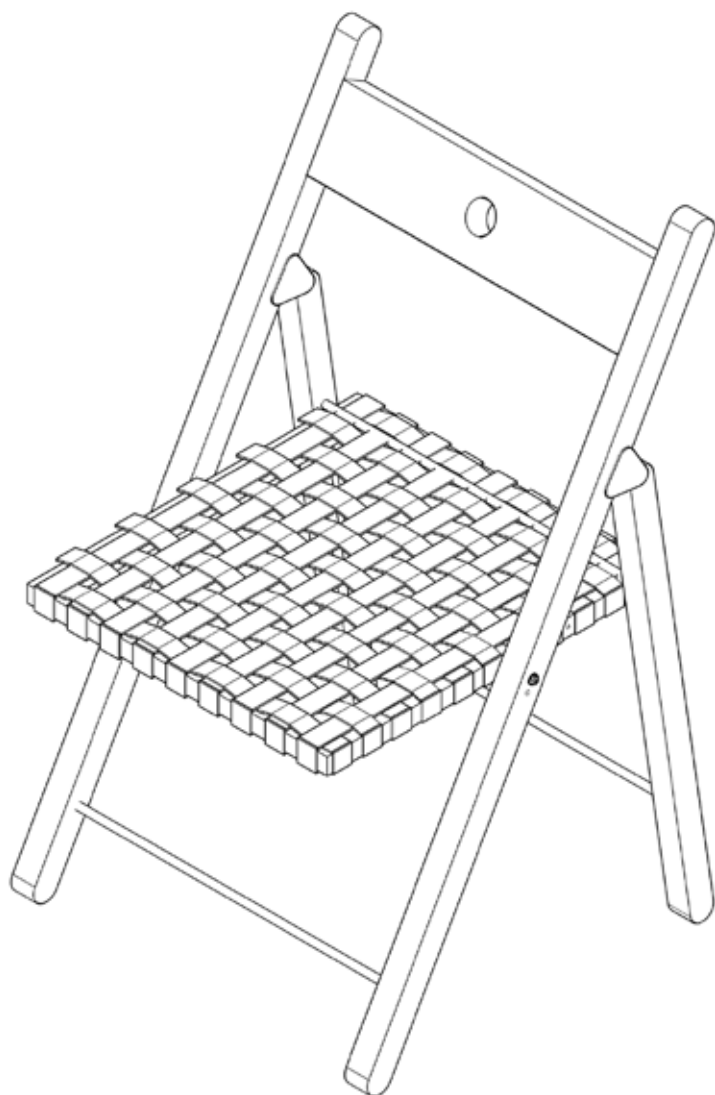
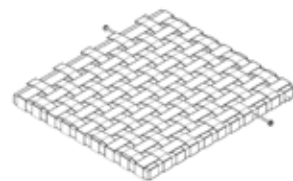

Pour terminer, il suffit d'assembler les deux parties créées.

N'hésitez pas à la pimper.

To finish, simply assemble the two parties created.

Don't hesitate to give it a twist.

DETAIL
DETAIL

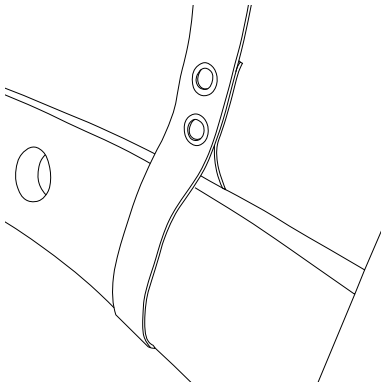

Nous avons choisi de rajouter une sangle afin de pouvoir porté la chaise. Pour ce faire, munissez-vous de votre sangle dimensionnée à la taille que vous souhaitez. Entourez le dossier et fixez là à l'aide de deux oeillets pour assurer sa résistance.

We have chosen to add a strap in order to carry the chair. To do this, take your strap and measure it to the size you want. Wrap it around the backrest and fix it with two eyelets to ensure its resistance.

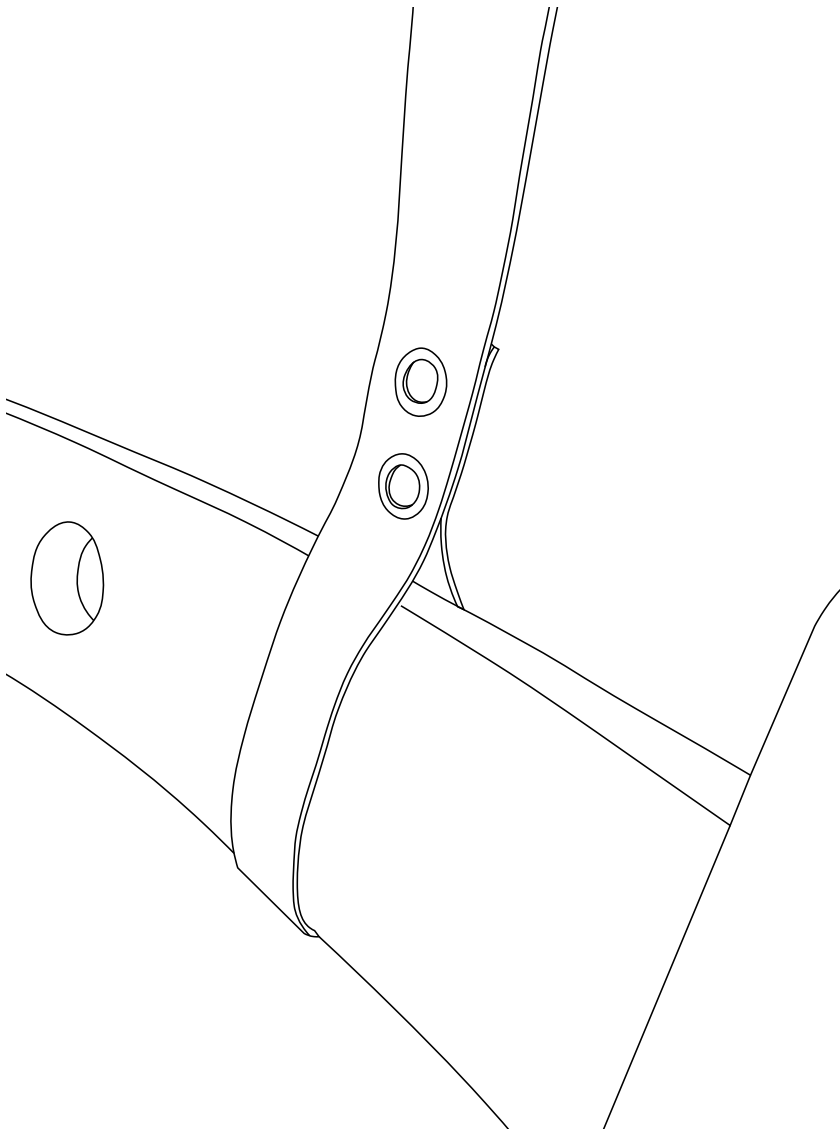

PLATEAU

PLATE

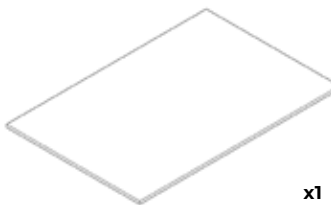
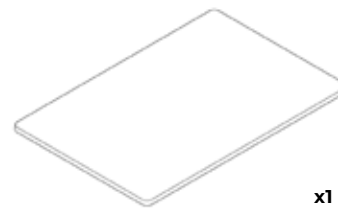
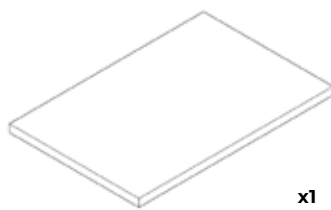
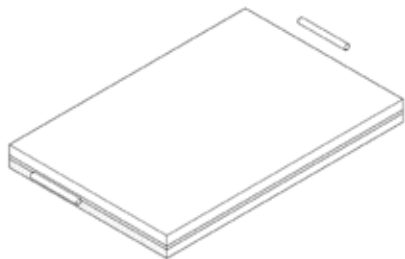

.1

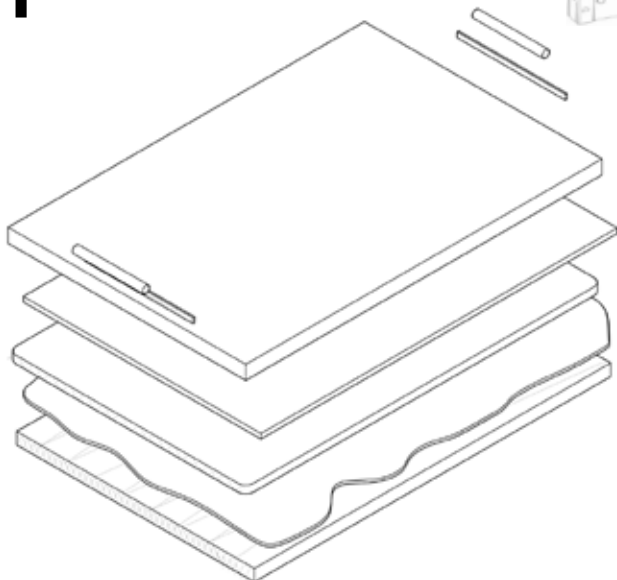

Afin de créer un plateau, coupez 2 planches à la dimension voulue. Taillez également la mousse à cette dimension.
Par la suite fixer la planche la plus fine et la mousse ensemble à l'aide de tissu. N'hésitez pas à utiliser une agrapheuse murale.

In order to create a tray, cut 2 planks to the desired size. Also cut the foam to this size.
Then fix the thinner board and the foam together with fabric. Do not hesitate to use a wall stapler.

.2

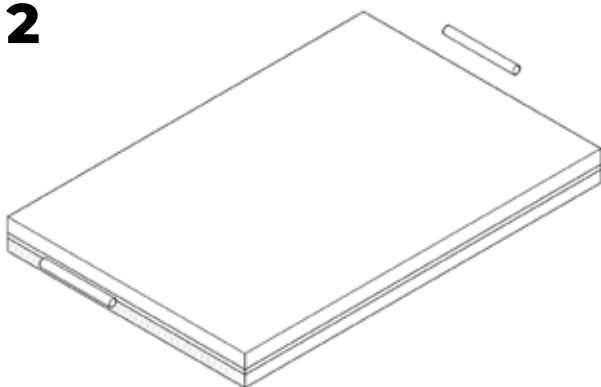

Vous pouvez désormais lier la plaque restante à cette partie en insérant des poignets entre elles-deux en utilisant une colle à bois et des serres-joints.

You can now join the remaining plate to this part by inserting cuffs between them using wood glue and clamps.

RITUAL BOWL





ORIGINAL OBJECT.

COOKING RITUAL.

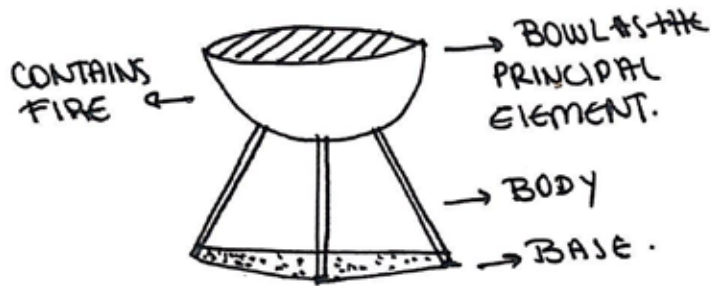

COOKING IS A HUMAN RITUAL
THAT REUNITES



RITUALISTIC BOWL

→ 2 FUNCTIONS

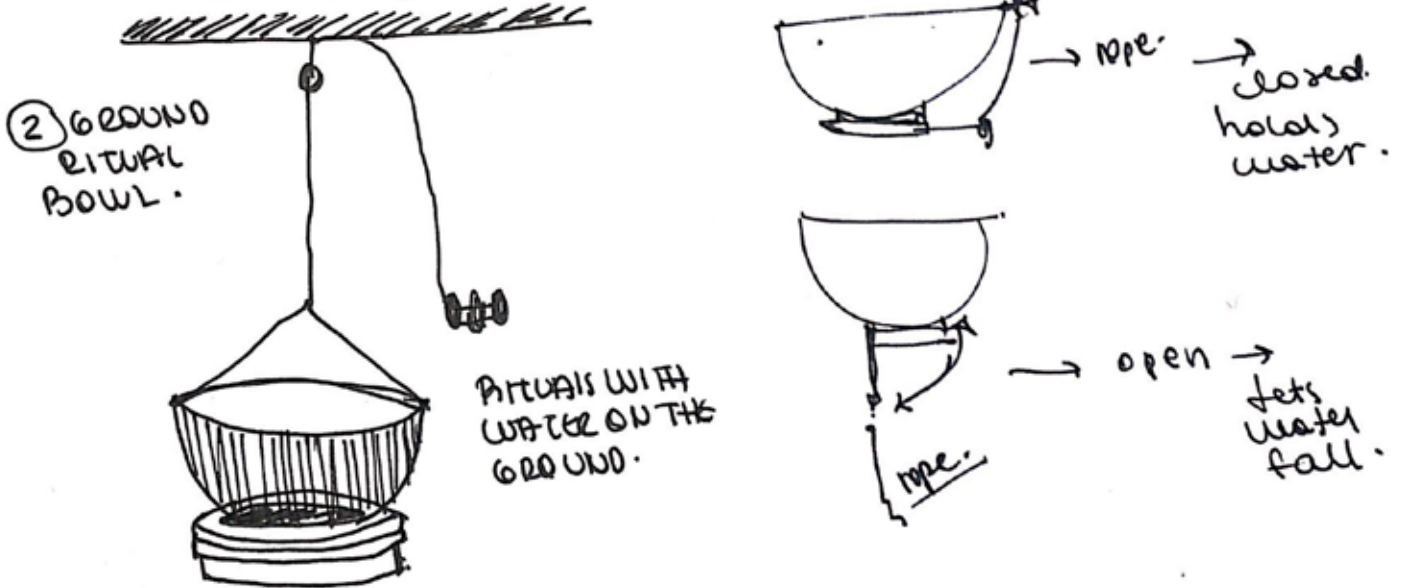

RITUALISTIC BOWL

→ 2 FUNCTIONS

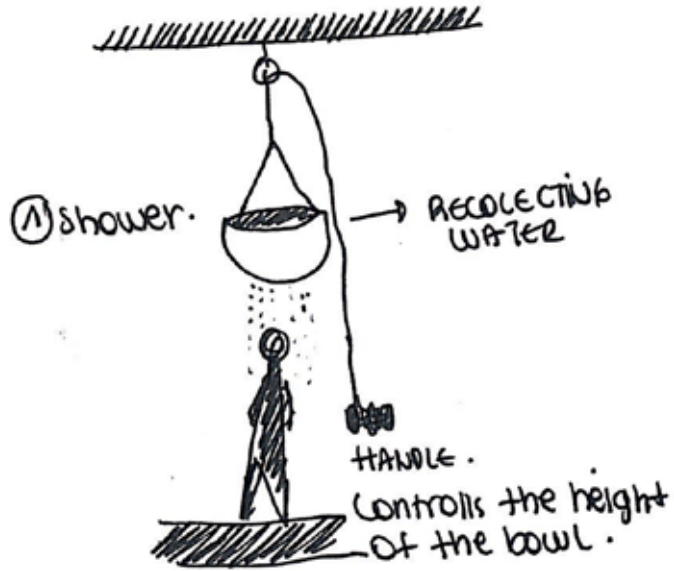

GROUND RITUAL BOWL.



SHOWER.

5 SOLUTIONS IN ORDER THE RITUAL BOWLS BECOMES A LUG.





ALCOHOLICS ANONYMOUS



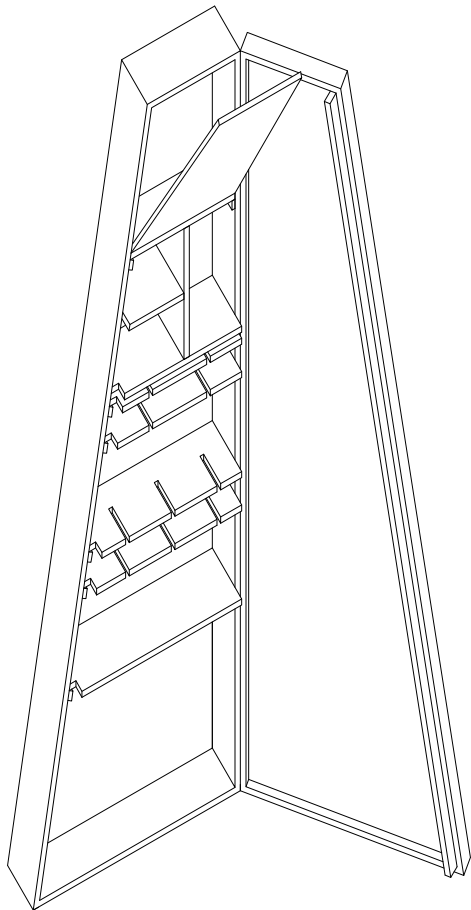
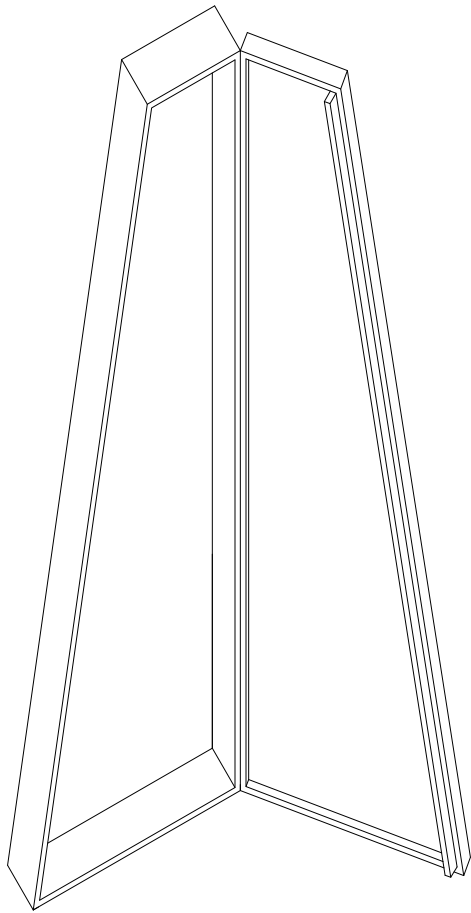



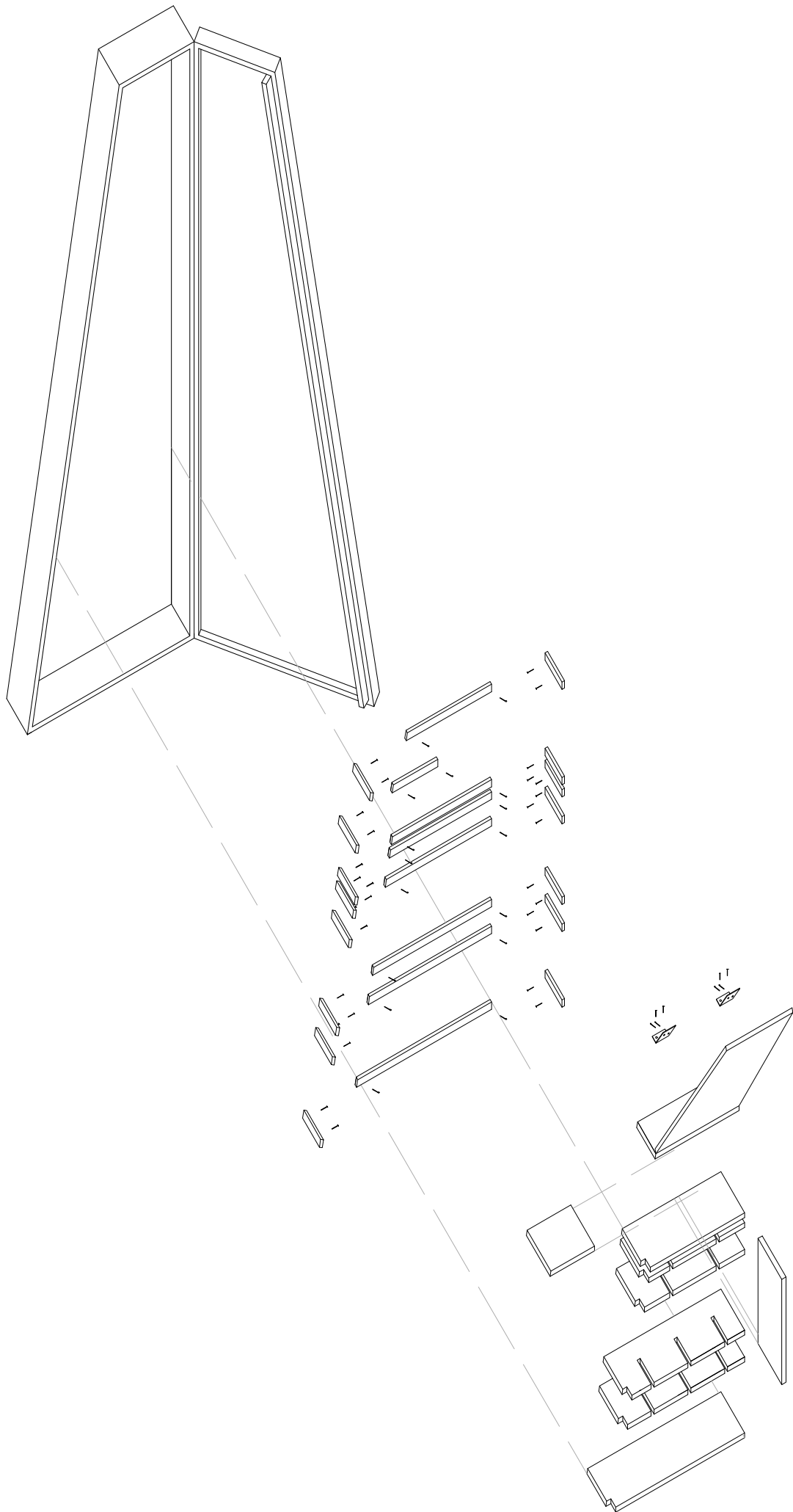



CEMOMACHINE



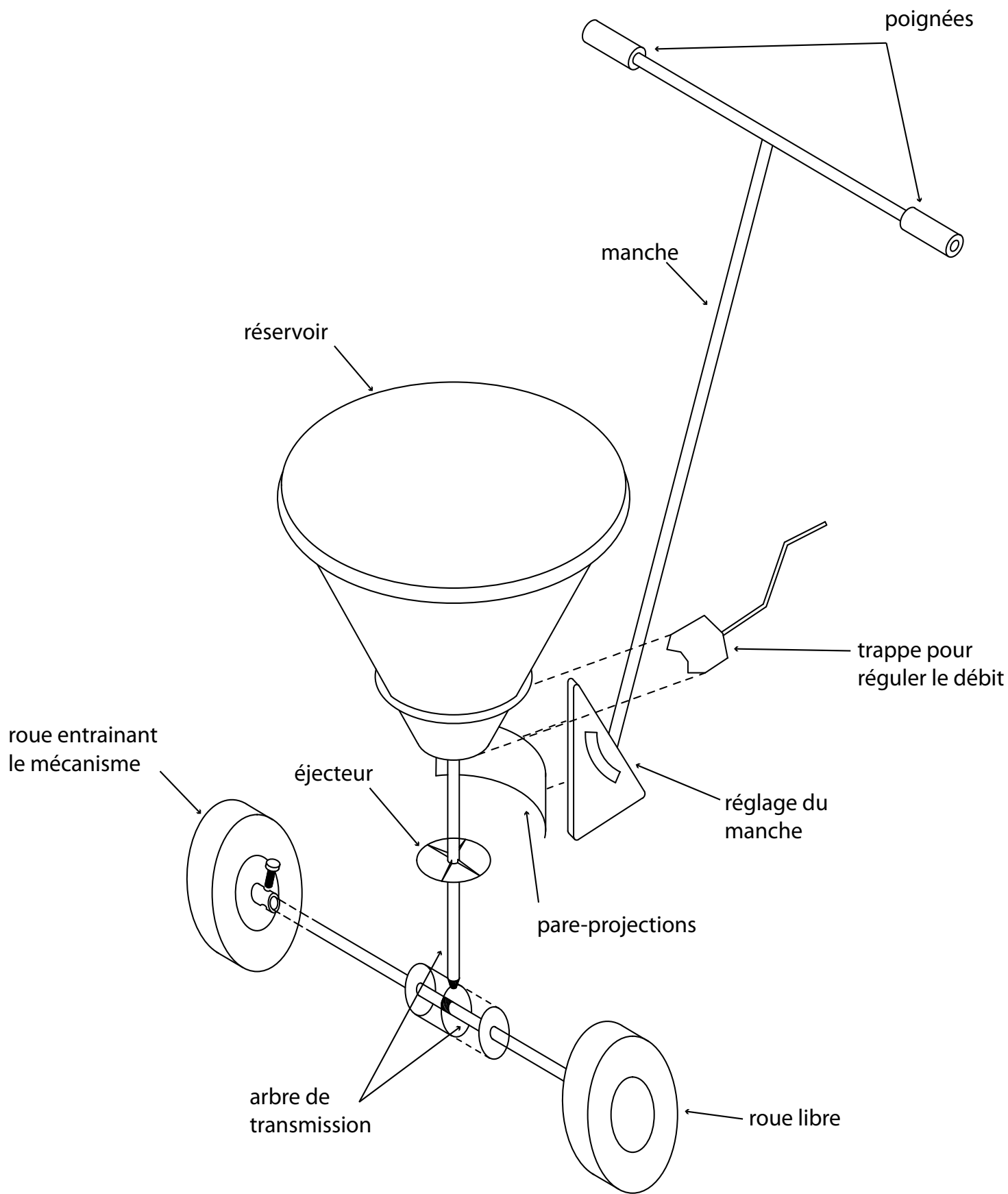

ÉPANDEUR

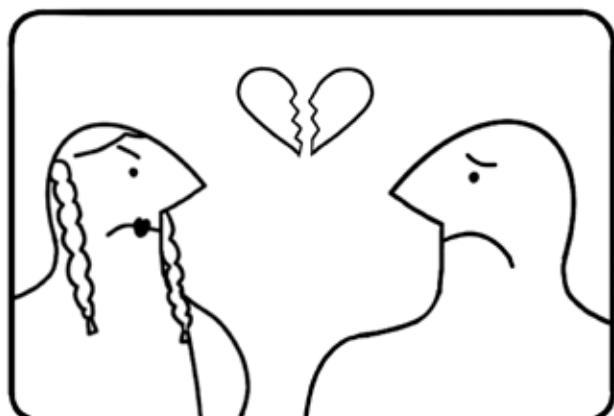
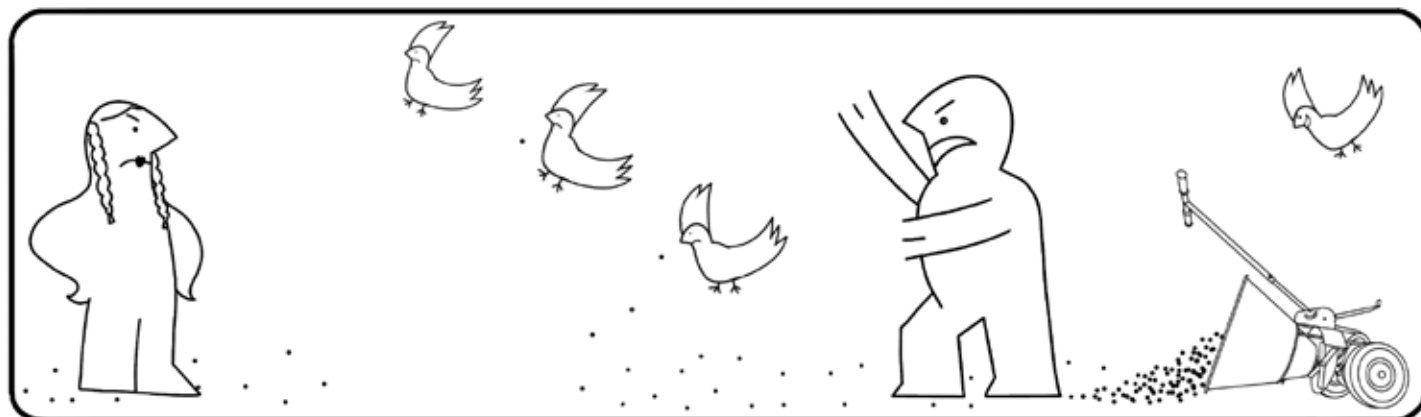
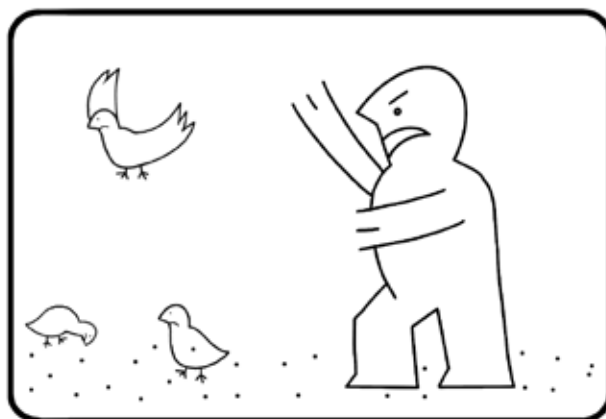
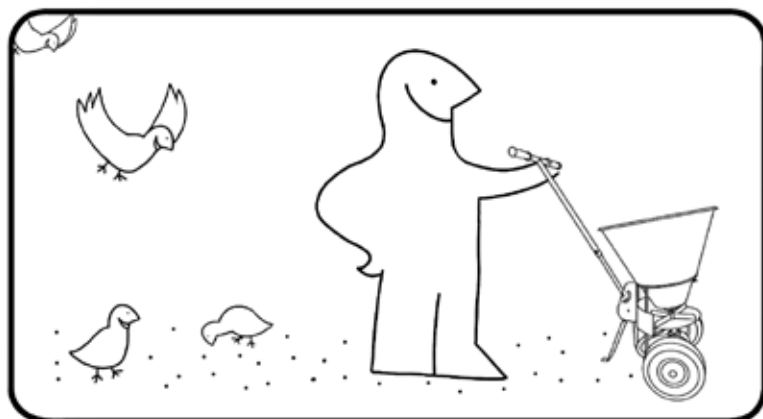
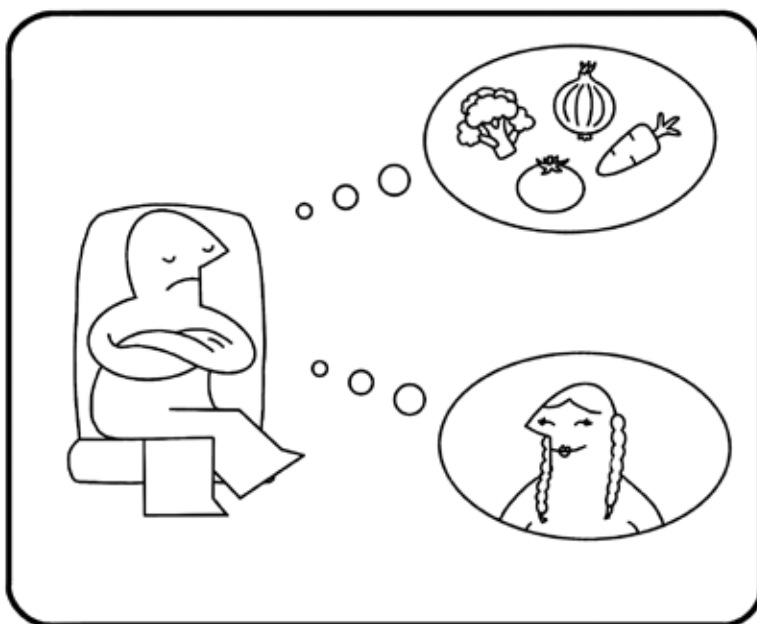
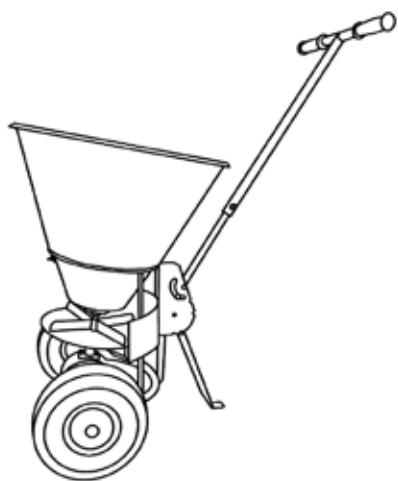

... **CEMO ?**



JEU DANS LE GUIDON
→ resserrer

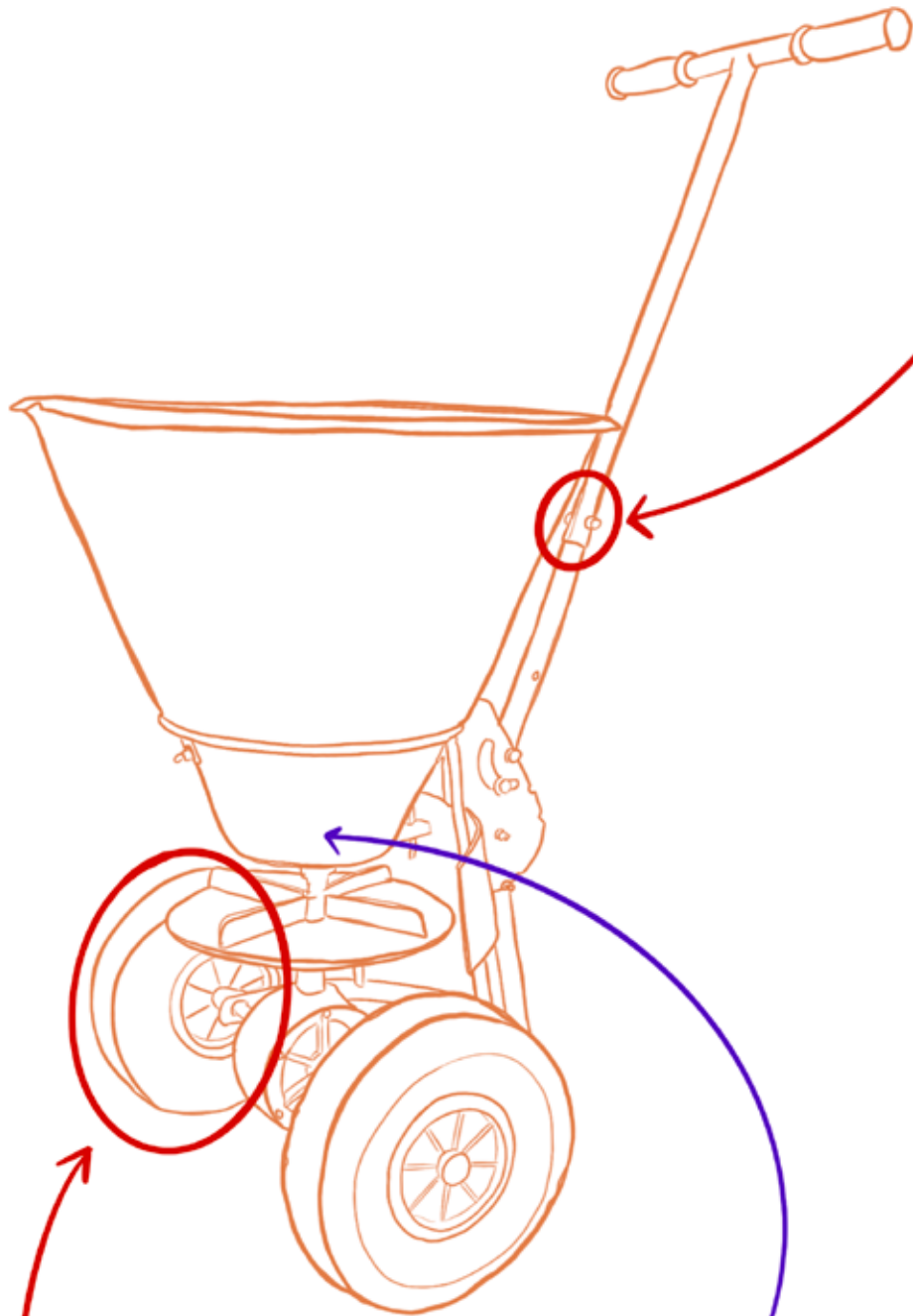

~~ROUE QUI ENCLANCHE
LE SYSTEME DE ROTATION
BLOQUEE~~

NON!

FIL DE FER BLOQUE
LE ROULEMENT
→ EASIER!!!



CEMO

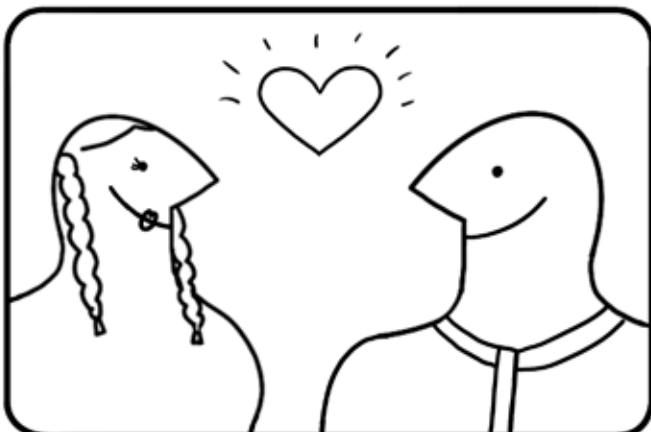
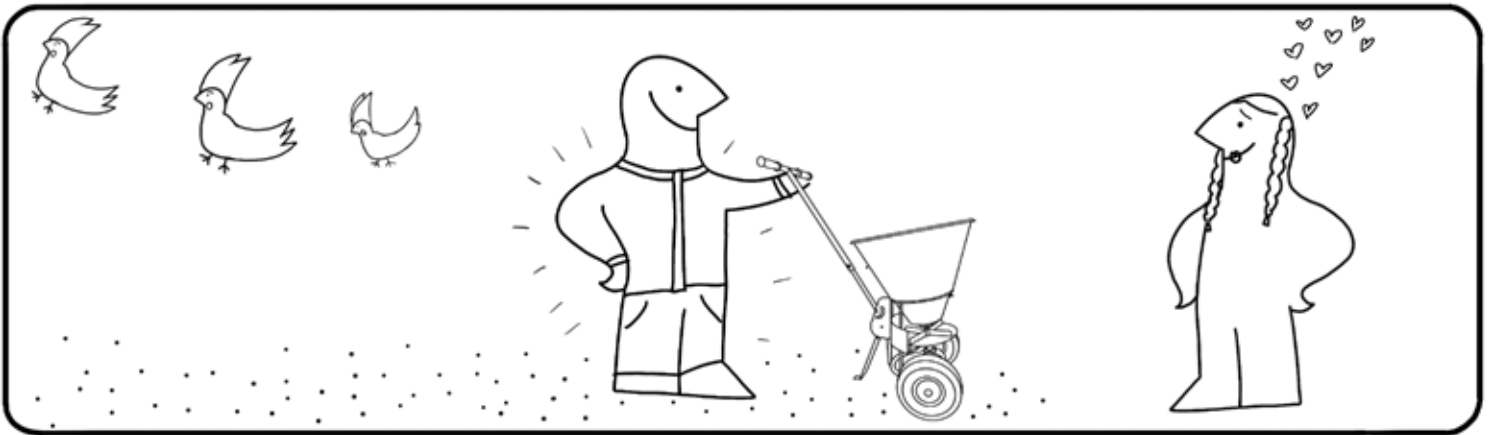
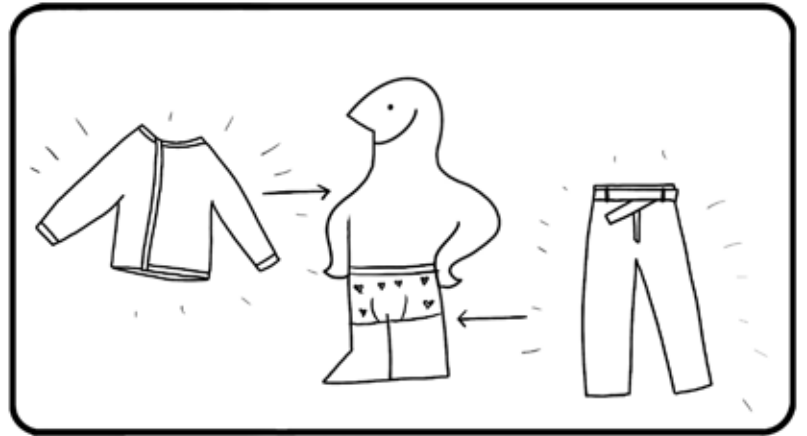
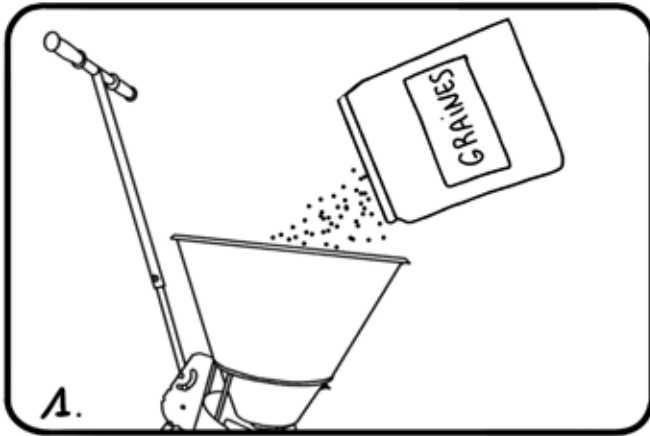
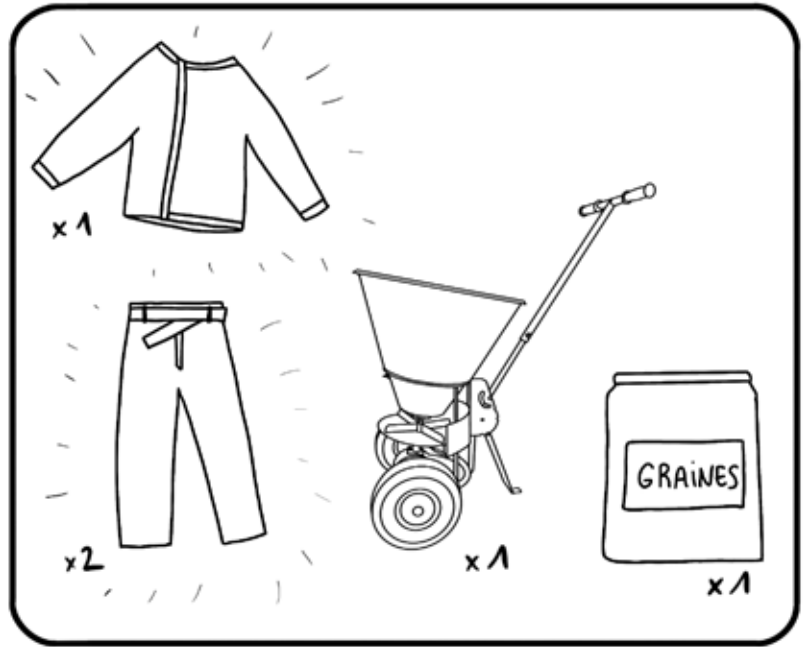
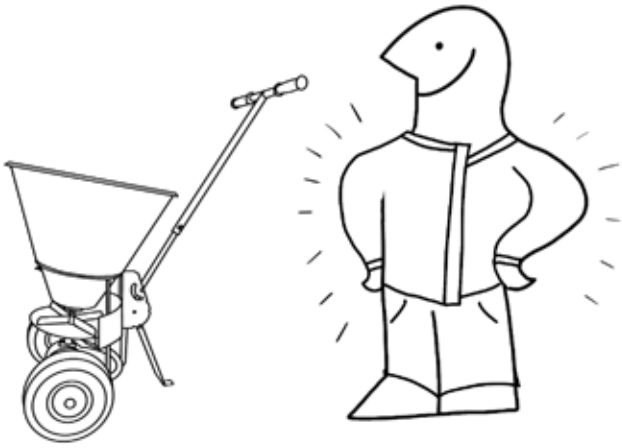

CEMO ! *With seeds and love*



STAGECHAIR







TREETA BLE



TASSEAMU

1000

TA33EAMW

TA35EA

TA33
EAMW



UNISEXLOCK

Faite d'enseignants
de la 1ère à la 3ème année
Paris 13e

**Discrimination, harcèlement,
violences, agissements
à caractère sexuel ou sexiste ?**
Ne restez pas sans réagir !
Victime ou témoin,
vous n'êtes pas seule(s)

Des « sentinelles » Égalité ont été nommées à l'École.
Elles sont à votre écoute afin de vous guider
et vous aider dans les cas de discriminations,
de harcèlement, de violences ou d'agissements
à caractère sexuel ou sexiste.
Vous pouvez les saisir via le QR code ci-dessous.



PREA LAB RECRUTE

Tu es en 1ère, 2ème, 3ème année ou
en master et tu es :

- 1. Étudiant(e) dans une école de la région Île de France
- 2. Étudiant(e) en formation initiale ou continue
- 3. Étudiant(e) en formation professionnelle
- 4. Étudiant(e) en formation de type BTS, DUT, Licence professionnelle

Rejoins nous !

01 42 42 42 42
prea@univ-paris13.fr
L'axe de la 13e

UNIVERSAL SEAT



UNIVERSAL SEAT

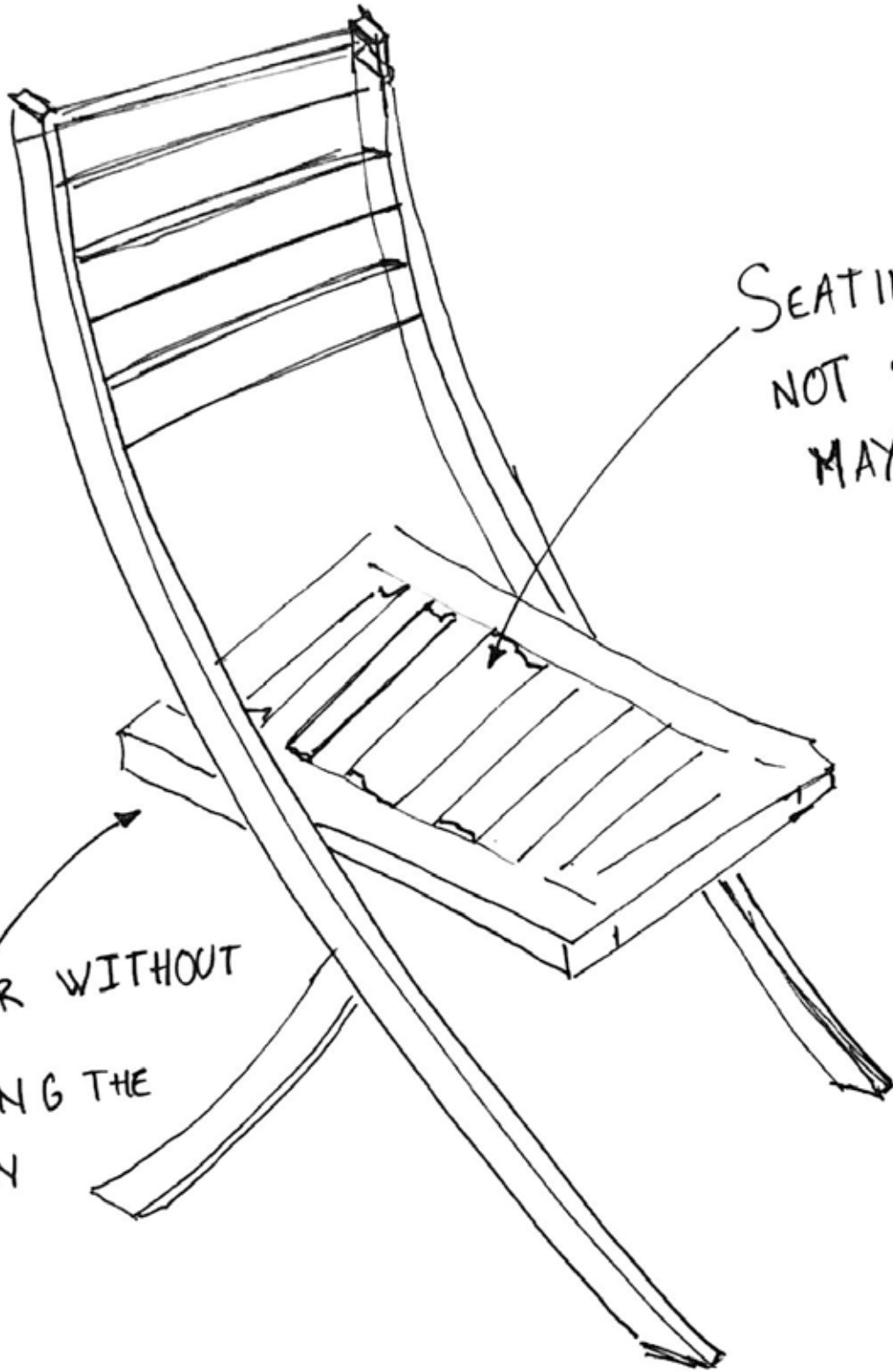

SEATING PART IS
NOT STABLE,
MAY BROKE.

REPAIR WITHOUT
TOUCHING THE
BROKEN
PART

• PIECE OF WOOD



• USE A JIGSAW TO CUT THE PIECE OF WOOD WITH THE GOOD DIMENSIONS

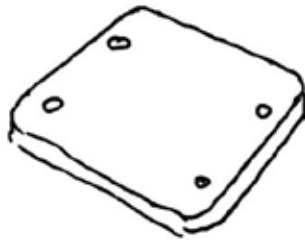
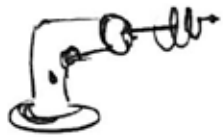
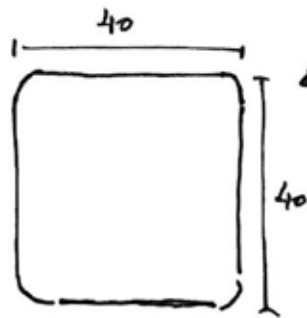

• MAKE 4 HOLES IN THE NEW SEAT

• USE SOME STRAPS TO MAKE THE UNIVERSAL SEAT



• FIND A SWIFT OPENING BUCKLE FOR STRAP



• ASSEMBLE THE BUCKLE AND THE STRAP



• NOW THIS UNIVERSAL SEAT CAN REPAIR ANY BROKEN SEAT!

LEISURETABLE





CHERMÉ-TEAM









École d'architecture
de la ville & des territoires
Paris-Est





hantimon quadrato







Consignes de sécurité

1. Les personnels administratifs et les enseignants présents dans l'école organisent l'évacuation. Les personnels administratifs volontaires dans l'école prennent en début d'année universitaire les consignes relatives à l'évacuation et ont ainsi identifié leur rôle d'intervenant, ils jouent à la fois le rôle de guide et sont identifiables par le port d'un gilet jaune.

2. Les personnes présentes sont évacuées au point de rassemblement ou le parking identifiable par ce pictogramme :



3. Pour les personnes en situation de handicap en cas d'impossibilité d'évacuation au point de rassemblement, elles sont mises à l'abri dans les locaux de l'établissement dans les espaces sécurisés à chaque niveau et signalés par ce pictogramme :















